

DESCRIPTION

A screw-in , cartridge-style , direct-acting , poppet-type , hydraulic relief valve intended for lower flow circuits requiring low internal leakage.

OPERATION

The RV08-2A blocks flow from 1 to 2 until sufficient pressure is present at 1 to force the spring-opposed poppet from its seat.

SYMBOL

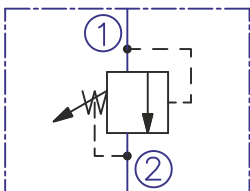

PERFORMANCE

Cartridge only
32cSt oil at 40°C

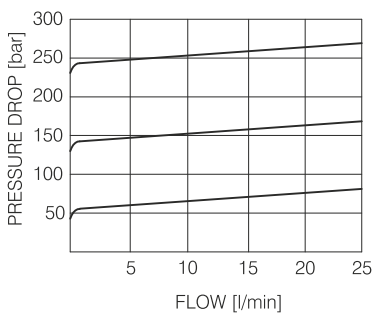

The Performance Chart illustrates flow handling capacity at max. setting for each spring range option. Pressure rise will vary with spring (range) and with setting within range due to flow forces.



DIMENSIONS

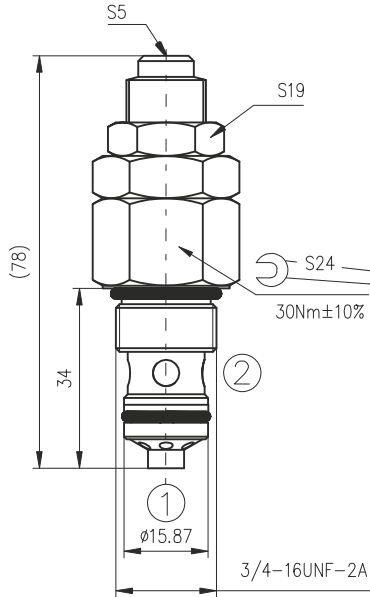

ORDERING CODE

RV08-2A *** **

Relief valve

Pressure adjustment range:

10...80bar - 8

40...160bar - 16

80...250bar - 25

Seals:

Buna N - N

Viton V - V

TECHNICAL DATA

Operating pressure		250bar
Pressure adjustment range:	RV08-2A8...	10...80 bar
	RV08-2A16...	40...160 bar
	RV08-2A25...	80...250 bar
Rated flow - See Performance Chart		
Internal leakage:		0,25cc/minute at 200bar max. to 75% of nominal setting
Working liquid-hydraulic oils with characteristics:		
-viscosity		10...400 cSt
-degree of filtration		0,025 mm
-temperature		-20...+80°C
Cavity: See "Cavities and bodies" brochure		CC08-2